

# Reaction-Diffusion Computing Media based on Minority-Carrier Transport in Solid-State Semiconductor Devices

TETSUYA ASAI

Graduate School of Information Science and Technology, Hokkaido University,  
Kita 14, Nishi 9, Kita-ku, Sapporo 060-0814, Japan  
phone : +81-11-706-6080, fax : +81-11-706-7890  
e-mail: asai@sapiens-ei.eng.hokudai.ac.jp

## 1. Introduction

Despite dramatic technological progress of digital processors and semiconductor integrated circuits, fundamental principles of their computing operations remain unchanged for the decades: the computational devices have “rigid” physical architectures vulnerable to almost any kind of damage and the perform calculation in a systematic fashion under precise timing control. Natural systems give us examples of amorphous, unstructured, devices capable for fault-tolerant information processing particularly with regard to massive parallel spatial problems that digital processors are rather weak in.

Reaction-diffusion (RD) chemical systems are well know now for their unique ability to efficiently solve combinatorial problems with natural parallelism [1]. In liquid-phase parallel processors, both the data and the results of the computation are encoded as concentration profiles of the reagents, the computation *per se* is performed via the spreading and interaction of wave fronts. In experimental chemical processors data are represented by local disturbances of concentrations and computation is implemented via the interaction of waves caused by the local disturbances. The RD chemical computers are parallel because the chemical medium’s micro-volumes update their states simultaneously, and molecules diffuse and react in parallel.

Practical value of RD chemical systems are significantly reduced by low speed of traveling waves which makes real-time computation senseless. One of the cost-efficient options to overcome the speed-limitations of RD computers while preserving unique features of wave-based computing is to implement RD chemical computers in silicon. The velocity of traveling wavefronts in typical reaction diffusion systems, e.g., BZ reaction, is  $10^{-2}$  m/s [3], while that of a hardware RD system will be over a million times faster than that of the BZ reaction, independent of system size [2, 4]. The increase in speed will be indispensable for developers of RD computers. Moreover, if a RD system is implemented in integrated circuits, then we would be able to artificially design various types RD spatio-temporal dynamics (the types may never occur in real-life chemical systems) and thus develop parallel computing processors for novel applications. Basing on experimental evidences of RD-like behaviour, namely traveling current density filaments [5, 6], in *p-n-p-n* devices we propose a novel type of semiconductor RD computing device, where minority carriers diffuse as chemical species and reaction elements are represented by *p-n-p-n* diodes.

## 2. The Reaction-Diffusion Device

The proposed RD device consists of a number of reaction devices regularly arranged on a common silicon substrate, as shown in Fig. 1. Minority carriers produced by a reaction device will travel through the substrate by diffusion and reach the adjacent reaction devices to activate them.

A reaction device we propose is illustrated in Fig. 2. The device is constructed by four regions; i.e., *p+*, *n*-well, *p*-sub, and *n+* regions. Figure 3 shows the cross-sectional view of the device along with a dashed line *A* in Fig. 2. A lateral *p-n-p-n* diode is formed beneath the substrate surface. The diode is connected with a capacitor and a *p*MOS FET acting as a current source. Figure 4 shows its equivalent circuit. The reaction device exhibits excitatory (monostable) behavior if the supply voltage *V*<sub>DD</sub> is lower than breakover voltage *V*<sub>*b*</sub> of the *p-n-p-n* diode. Namely, the capacitor voltage *v* cannot reach *V*<sub>*b*</sub> because *v* does not exceed supply voltage *V*<sub>DD</sub> (bias current becomes 0 when *v* increases up to *V*<sub>DD</sub>). The *p-n-p-n* diode turns on only when minority carriers are injected out of the device.

The state of the reaction device can be represented by two variables, i.e., the capacitor voltage (the charge stored on the capacitor) and the concentration of minority-carriers (electrons) in the *p*-sub region of the *p-n-p-n* diode. We modeled the dynamics of the reaction device as

$$C \frac{dv}{dt} = I_0 i(v) - \frac{v}{r(v, n)}, \quad q \frac{dn}{dt} = -q \frac{n}{\tau} + \frac{v}{r(v, n)}, \quad (1)$$

where *C* represents the capacitance, *v* the capacitor voltage, *n* the minority carrier concentration, *I*<sub>0</sub> *i*(*v*) the current of the *p*MOS FET, *q* the charge of electron and *τ* the minority carrier lifetime. The characteristic of the *p-n-p-n* diode is represented by nonlinear resistance *r*(*v*, *n*). The minority carrier concentration *n* increases through a multiplication process caused by the feedback mechanism of the *p-n-p-n* diode, while capacitor charge decreases by the amount equal to the increased minority carriers. Since the charge of the capacitor is depleted by the *p-n-p-n* device, this device imitates a substrate-depleted reaction.

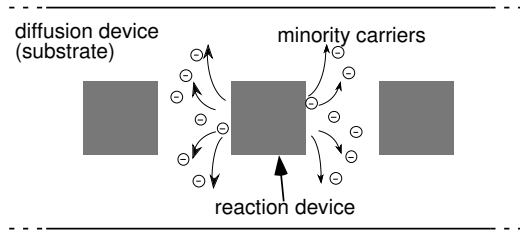

**Fig. 1** Schematic image of the RD device

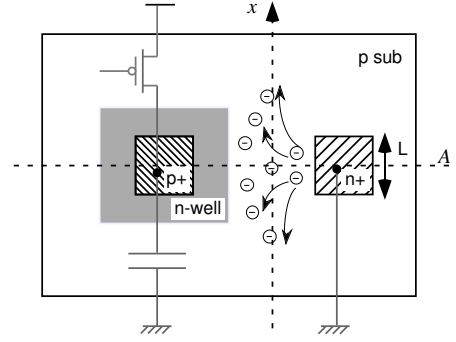

**Fig. 2** The proposed reaction device (top view)

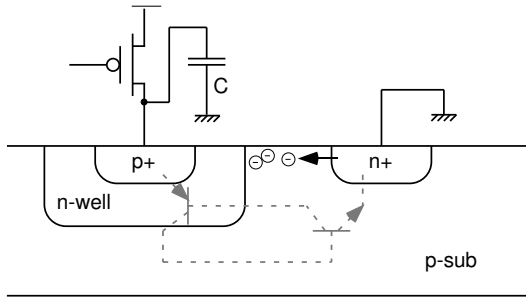

**Fig. 3** The reaction device (cross-sectional view)

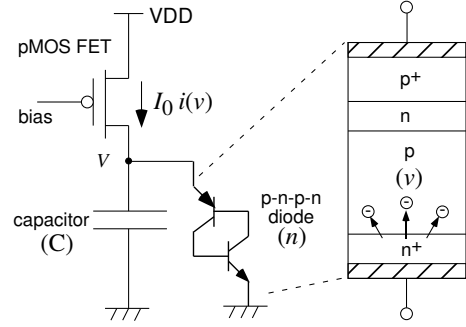

**Fig. 4** Equivalent circuit of the reaction device

We designed one-dimensional RD device by arranging the reaction devices on a silicon substrate, as shown in Fig. 5. Minority-carriers (electrons) produced by a reaction device will travel through the  $p$ -sub region by diffusion and reach adjacent devices. When the reaction devices are closely arranged on the substrate, these minority carriers induce a chain reaction among the reaction devices. We estimate the minimum distance between adjacent devices to cause the chain reaction.

The minority carrier concentration along with the  $x$ -axis in Fig. 2 is given by

$$\frac{\partial n(x, t)}{\partial t} = D_n \frac{\partial^2 n}{\partial x^2} - \frac{n}{\tau}, \quad (2)$$

where  $D_n$  is the diffusion coefficient ( $=\mu_n kT/q$ ). The impulse response to Eq. (2) is obtained as

$$g(x) = \frac{1}{\sqrt{4\pi D_n t}} \exp\left(-\frac{x^2}{4D_n t} - \frac{t}{\tau}\right). \quad (3)$$

When a reaction device turns on at  $t = 0$ , the minority carrier concentrates around the reaction device (Fig. 6). The total amount of the minority carriers in the  $p$ - $n$ - $p$ - $n$  diode is assumed to be equal to the charge of the capacitor at  $t = 0$ . The minority carrier distribution  $n(x, t)$  is thus obtained as

$$n(x, t) = n(x, 0) * g(x) = \frac{N_0}{2} \exp\left(-\frac{t}{\tau}\right) \left[ \operatorname{erf}\left(\frac{x + L/2}{\sqrt{4D_n t}}\right) - \operatorname{erf}\left(\frac{x - L/2}{\sqrt{4D_n t}}\right) \right], \quad (4)$$

where  $L$  and  $N_0$  represent the length of the reaction device (See Fig. 2) and the total amount of the charge of the capacitor ( $= C VDD / q$ ), respectively.

Let us assume that the reaction device turns on when the total amount of the minority carriers in the  $p$ - $n$ - $p$ - $n$  diode exceeds the amount of  $\alpha N_0$  (See Fig. 6). Then, minority carriers produced by a reaction device (R1 in Fig. 6) can turn on its adjacent device (R2 in Fig. 6) when

$$\int_{D+L/2}^{\infty} n(x, t) \geq \alpha N_0 \quad (5)$$

where  $D$  is the distance between adjacent reaction devices. With a given  $\alpha$ , one can estimate the RD device geometries ( $L$  and  $D$ ). Figure 7 shows example plots of Eq. (4) with practical device parameters [ $D_n = 39 \text{ cm}^2/\text{s}$  ( $\mu_n = 1500 \text{ cm}^2/\text{V s}$ ),  $\tau = 1 \text{ }\mu\text{s}$  and  $L = 20 \text{ }\mu\text{m}$ ].

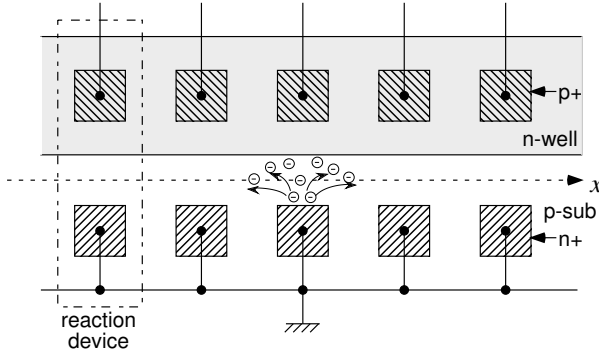

**Fig. 5** The RD device consisting of 1-D array of reaction devices

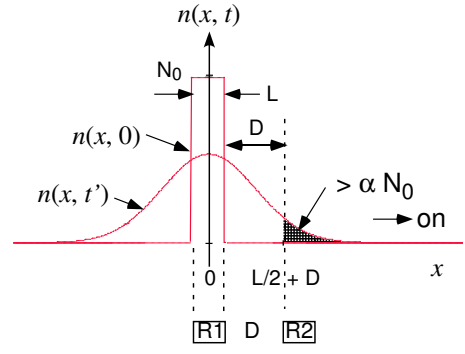

**Fig. 6** Turn on condition of R2 through R1 and D

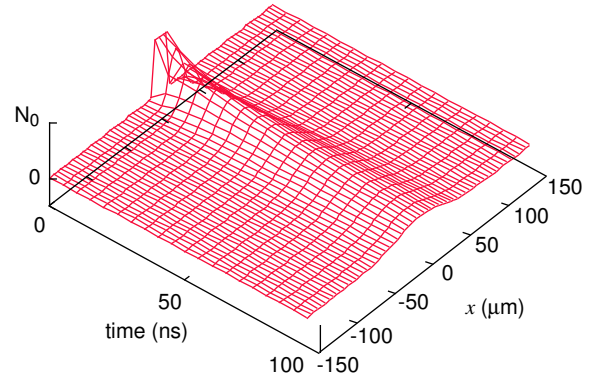
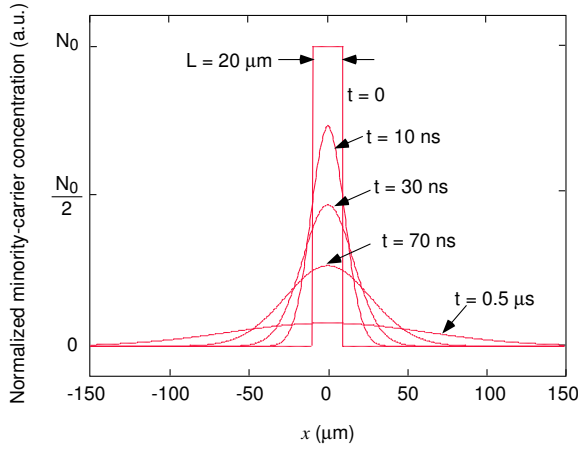

**Fig. 7** Minority-carrier diffusion in the single reaction device.

### 3. Simulation Results

We confirmed the operation of the one-dimensional RD system by numerical simulations. The RD equation was obtained along with the  $x$ -axis in Fig. 5. At the position of each reaction device, we used the following RD equations that describe spatiotemporal dynamics of the reaction device:

$$\begin{aligned}\frac{\partial U}{\partial t_1} &= k i(U) - \frac{U}{\tau_1(U, V)}, \\ \frac{\partial V}{\partial t_1} &= \tau D_n \frac{\partial^2 V}{\partial x^2} - V + \frac{U}{\tau_1(U, V)},\end{aligned}$$

where  $k i(U)$ ,  $U$ ,  $V$  and  $t_1$  are the normalized current [ $k = \tau I_0 / (C \text{ VDD})$ ], the normalized capacitor voltage ( $U \equiv n/N_0$ ), the normalized minority-carrier concentration ( $V \equiv n/N_0$ ) and the normalized time ( $t_1 = t/\tau$ ), respectively. In other positions where no reaction device exists, we used the following equations:

$$\frac{\partial U}{\partial t_1} = 0, \quad \frac{\partial V}{\partial t_1} = \tau D_n \frac{\partial^2 V}{\partial x^2} - V.$$

We solved these equations numerically using the conventional FDTD method.

Figure 8 shows a result for a RD device with nine reaction devices. In the simulations, we assume  $\alpha = 0.1$  and  $D = 20 \mu\text{m}$ . The rest parameters are set at the same values with the device parameters shown in Fig. 7. In Fig. 8, horizontal and vertical axes represent the space and the time, respectively. The position of the reaction device is indicated by  $R$  in the rectangle waves.

At an initial state ( $t = 0$ ), a center reaction device produced minority carriers. The carriers are diffused around the reaction device, and at  $t \approx 25 \text{ ns}$ , its adjacent devices are turned on (activated). They produce minority carriers as well, then at  $t \approx 50 \text{ ns}$  (80 ns), their adjacent reaction devices are activated. The propagating waves are produced in the form of the propagation of the activations of reaction devices.

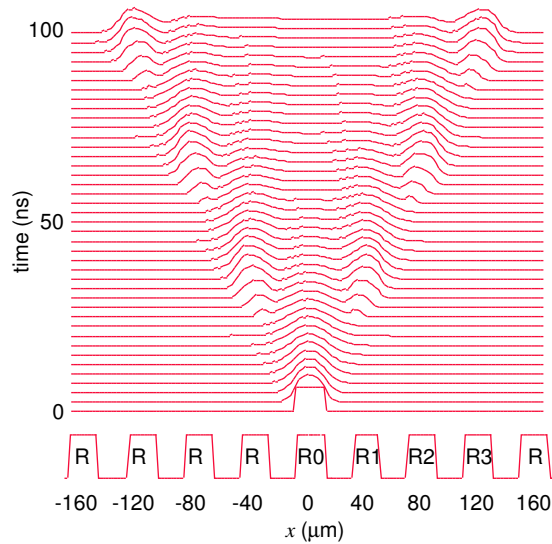

Fig. 8 Reaction-diffusion simulation results of the 1-D RD device

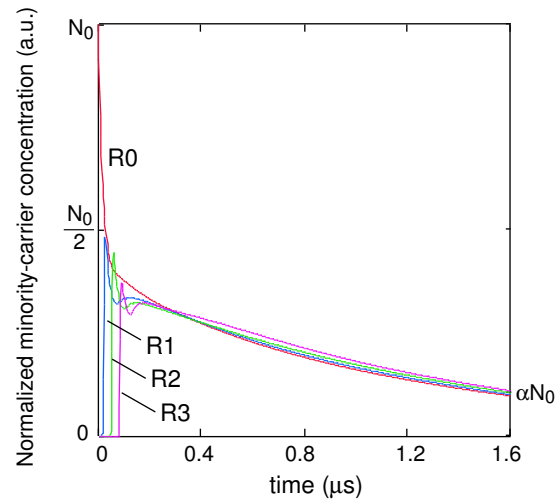

Fig. 9 Time course of the concentration of the center device

Very slow decay of the minority carrier concentration was observed in a reaction device being activated by its adjacent device. Figure 9 shows time course of the concentration of the reaction device (R0 to R3 in Fig. 8). The refractory period was the order of  $1 \mu\text{s}$ . It was approximately hundred times as long as the propagating time between the adjacent reaction devices. Note that the decay time can be controlled by ejecting minority carriers from the  $p$ -sub region.

#### 4. Summary

We proposed a novel silicon device for imitating autocatalytic and dissipative phenomena of the reaction-diffusion (RD) systems. Numerical simulations showed that the proposed RD device can successfully produce propagating waves in the same way as natural RD systems. Our results indicate that the proposed RD device will be an useful tool for developing novel hardware based on the RD mechanism.

#### Acknowledgments

The authors wish to thank Professor Andrew Adamatzky of the University of the West of England for valuable discussions and suggestions during the research and Professor Yoshihito Amemiya of Hokkaido University for suggestions concerning various CMOS circuits. This study was supported in part by the Industrial Technology Research Grant Program in 2004 from the New Energy and Industrial Technology Development Organization (NEDO) of Japan and by a grant-in-aid for young scientists [(B)17760269] from the Ministry of Education, Culture, Sports, Science, and Technology (MEXT) of Japan.

#### References

- [1] Adamatzky A. Computing in Nonlinear Media and Automata Collectives. Bristol: Institute of Physics Publishing; 2001.
- [2] Adamatzky A., De Lacy Costello B, Asai T. Reaction-Diffusion Computers. London: Elsevier; 2005.
- [3] Tóth Á, Gáspár V, Showalter K. Propagation of Chemical Waves through Capillary Tubes. J Phys Chem 1994;98:522-531.
- [4] Asai T, Nishimiya Y, Amemiya Y. A CMOS reaction-diffusion circuit based on cellular-automaton processing emulating the Belousov-Zhabotinsky reaction. IEICE Trans Fundamentals of Electronics, Communications and Computer 2002;E85-A:2093-2096.
- [5] Niedernostheide FJ, Kreimer M, Schulze HJ, Purwins HG. Periodic and irregular spatio-temporal behaviour of current density filaments in Si  $p^+-n^+-p-n^-$  diodes. Phys Lett A 1993;180:113-118.
- [6] Niedernostheide FJ, Kreimer M, Kukuk B, Schulze HJ, Purwins HG. Travelling current density filaments in multilayered silicon devices. Phys Lett A 1994;191:285-290.