

A MOS Vision Chip Based on the Cellular-Automaton Processing

Tatsuhiko Sunayama^{*}, Tetsuya Asai^{*}, Yoshihito Amemiya^{*}, and Masayuki Ikebe[†]

^{*}Hokkaido University [†]Dai Nippon Printing Co., Ltd.

^{*} Kita 13, Nishi 8, Kita-ku, Sapporo, 060-8628, Japan [†] Ichigaya Kagacho 1-1-1, Shinjuku-ku, Tokyo, 162-8001, Japan
Phone: +81-11-706-7147, email: sunayama@sapiens-ei.eng.hokudai.ac.jp

1. Introduction

One of the promising areas of research in microelectronics is the development of novel image-processing devices based on parallel processing architectures. Using a silicon functional element known as the MOS FET, we developed one such processing device, namely, a *cellular-automaton image sensing LSI that performs noise cleaning and edge detection on input images*.

2. Cellular Automaton

The cellular automaton is a parallel data-processing system that consists of many identical processing elements (cells) arrayed uniformly on a plane (Fig.1). Each cell has a binary state, and all the cells change their states synchronously in discrete time steps. The subsequent state of the cell is determined from the current state of the cell and the current state of neighboring eight cells. A way of determining the subsequent cell state is called a *transition rule*. With appropriate transition rules, we can obtain useful pattern transformations. The operation of the cellular automaton is just same as the morphological picture processing in binary pictures if each cell and its state are regarded as a picture element and a black-white level of the picture element.

3. Implementing the Cellular Automaton onto Circuits

We implemented the cellular automaton onto electronic circuits to develop image-processing LSIs. As an example, we here present an image-sensor chip that performs *noise cleaning* and *edge detection* on input images. For these processings, three transition rules are required:

(i) *Dilation* and *Erosion*: these two rules are used for noise cleaning. The dilation is: set the center pixel to white if all the neighboring 8 cells are white; otherwise, set the center pixel to black. The erosion is: set the center pixel to black if all the neighboring 8 cells are black; otherwise, set the center pixel to white. With dilation, an object grows uniformly by a single-pixel-width ring of exterior pixels, while with erosion an object shrinks by a single-pixel-width ring of interior pixels. By combining dilation and erosion, we can remove noise from input images.

(ii) *Edge detection*: set the center pixel to white if all the neighboring 8 cells are black; otherwise, maintain the center pixel as it is. With this rule, the interior pixels of an object are converted to white, but the peripheral pixels are left black, and consequently, the edge of the object is extracted.

To implement these three rules into a compact cell circuit, we used a silicon functional element known as the MOS FET (see Ref. 1). The MOS FET is a variable-threshold logic device with multi-input gates and therefore can be well used for implementing the transition rules.

4. Constructing the Cell Circuit Using the MOS FET

The cell circuit we proposed is illustrated in Fig.2. It consists of three constituents: a photosensor, a MOS variable-threshold gate, and a cell-state memory. In a storage period (control signals $V3$ and $V4$ are set at 1 (Vdd)), the photosensor is connected with the memory through the multiplexer. It accepts an input luminance signal for the pixel and produces the binary-quantized data on node P . The memory stores the data (the current state of the cell) and sends the data to neighboring eight cells.

In a processing period ($V3$ is switched over to 0), the MOS threshold gate is connected with the memory through the multiplexer, and cellular-automaton processing starts. The MOS gate receives the current cell-state data as inputs ($Vin1$ through $Vin8$) from the neighboring cells and determines the subsequent state of its own cell according to the transition rule. The subsequent cell state is produced on node Q . The cell state in the memory is updated with clock CLK . The circuit switches the three transition rules according to control signals $V1$ and $V2$: the circuit operates in dilation if $V1 = V2 = 1$ (Vdd), in erosion if $V1 = 0$ and $V2 = 1$, and in edge detection if $V1 = V2 = 0$.

To retrieve the processed data, control signals $V3$ and $V4$ are set at 1. The cell circuit, then, operates as a simple shift register that receives the pixel data from the left-hand cell and passes it on to the right-hand cell with clocks. The processed image data on each row of cells is obtained in a form of a 1-0 bit stream that is output from the right-end cell.

5. Image Processing on the Cellular-Automaton Chip

By arranging the cell circuits into a 15×15 matrix, we fabricated a cellular-automaton image sensing LSI that performs noise cleaning and edge detection on input images. A 0.6- μm CMOS process was used. The chip photograph is illustrated in Fig.3. The size of the cell is $210 \mu\text{m} \times 200 \mu\text{m}$.

We confirmed the image processing of the LSI. The result is shown in Fig. 4. In this example, the input image is a letter "D" with noise (step 1 in Fig. 4). This noisy image is cleaned up with clocks through processings of dilation and erosion (steps 2-5), then the edge of the cleaned image is extracted (step 6). The final data on each row of cells is retrieved successfully as shown in Fig. 5. The chip was able to operate up to 10-MHz clock frequency.

(This work was partly supported by STARC.)

Reference

1. Shibata T. and Ohmi T., "A functional MOS transistor featuring gate-level weighted sum and threshold operations," *IEEE Trans. Electron Devices*, **39** (6), 1444-1455 (1992).

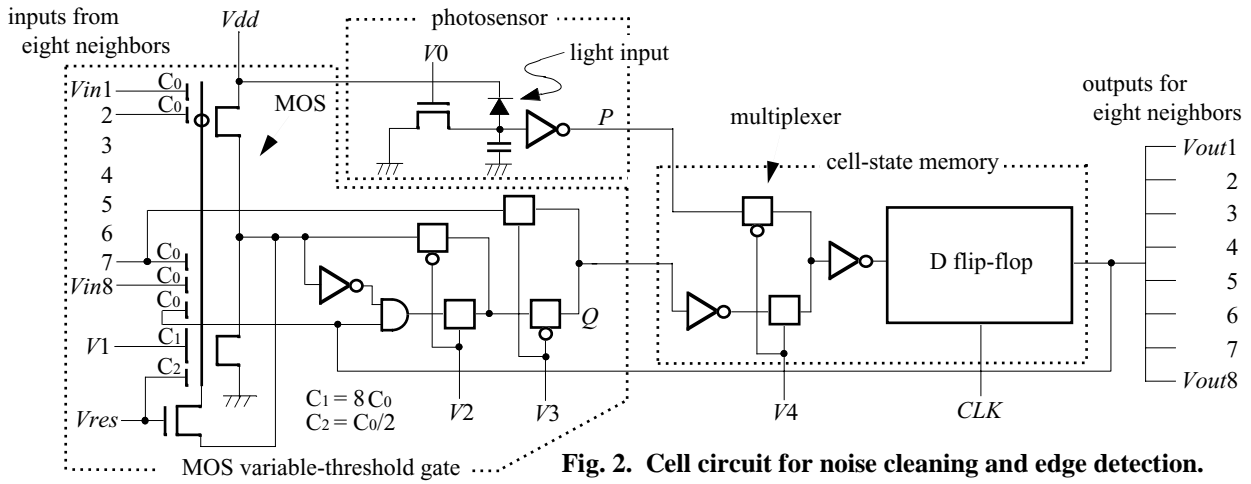

Fig. 2. Cell circuit for noise cleaning and edge detection.

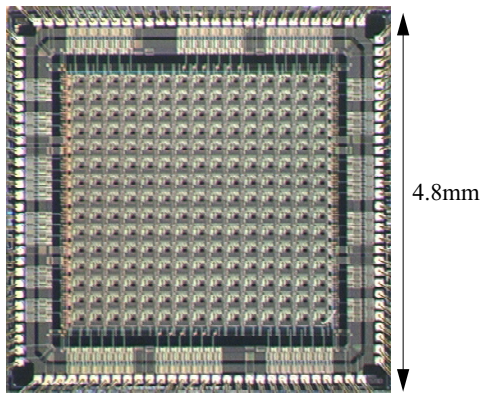

Fig. 3. Cellular-automaton vision chip.

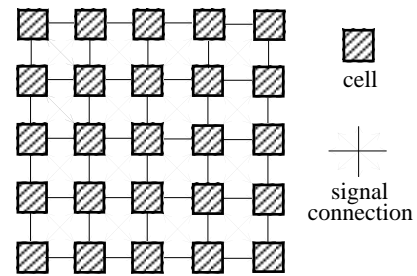

Fig. 1. Cellular automaton.

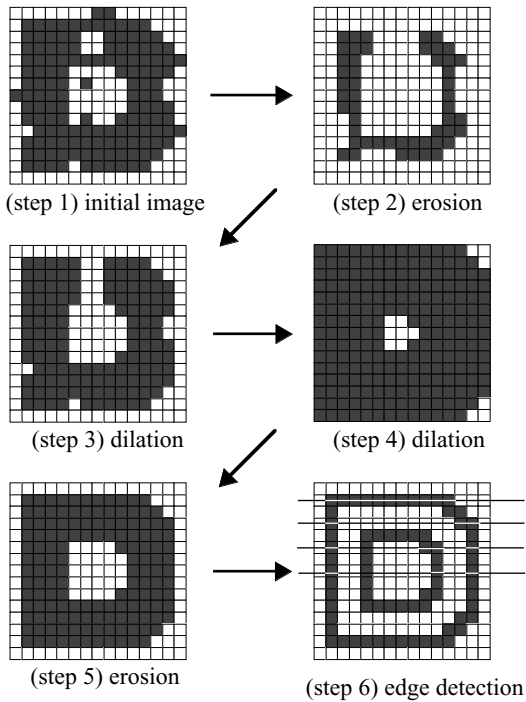

Fig. 4 Image processing on the chip.
 (noise cleaning plus edge detection)

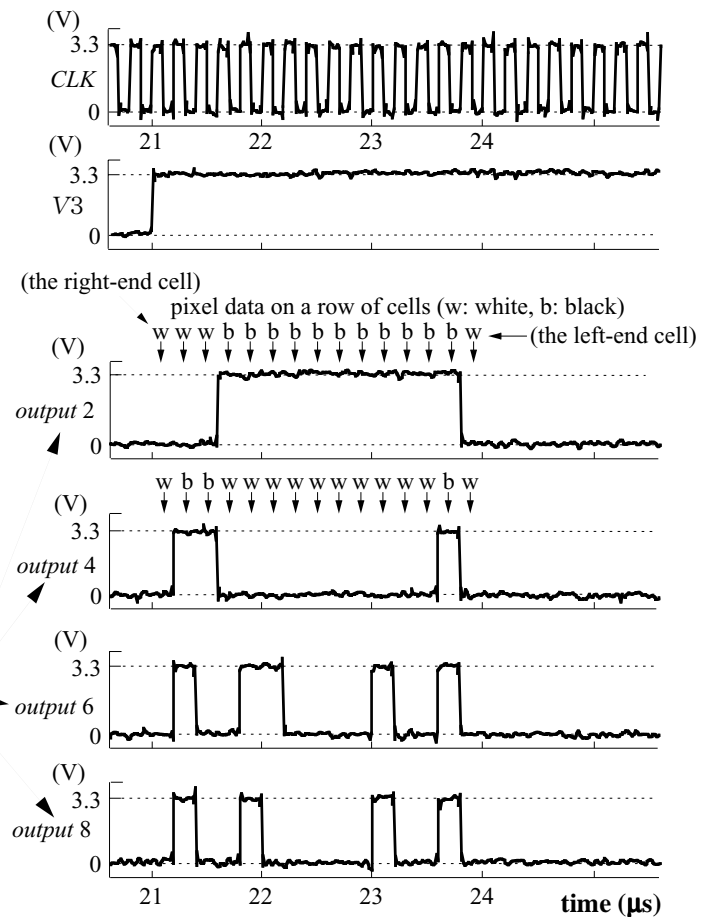

Fig. 5 Output waveforms for the processed data.